

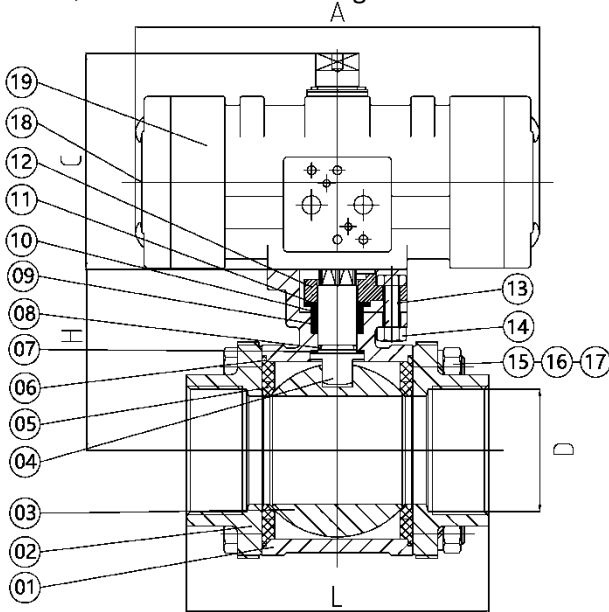

■ OPTION

- ▷ Fire safe design
- ▷ V-port (30°, 45°, 60°)
- ▷ DIN standard M3 length



Valve size	L	D	A	C	H
15A	73	16	107.3	74	48.5
20A	84	21	138	86	53.5
25A	87	26	138	86	58.5
32A	107.5	32	187	100	71
40A	120	40	203.5	100	76
50A	140	51	203.5	100	83.5

■ VALVE

- ▷ Working Pressure : 10kg/cm²
- ▷ Max Temperature : 80 °C
- ▷ Ball : Full bore
- ▷ Material : ASTM A351 - CF8(1.4308)
ASTM A351 - CF8M(1.4408)
- ▷ End connection
 - * Screwed : BS21 1973(BSPT)
ANSI B2.1(NPT)
DIN 259/2999
ISO 228
 - * Socket Weld : JIS B2316, ANSI B16.11
 - * Butt Weld (37.5°)
- ▷ ISO5211 Direct mounting pad
- ▷ Investment casting body & end cap

■ ACTUATOR

- ▷ Double Acting
- ▷ Spring Return
- ▷ Accessories :
 - + Solenoid valve with Neon lamp(IP65)
 - + Limit switch box(Weather, Explosion proof)
 - + Air Filter regulator unit
 - + Speed controller
 - + Silencer
 - + One touch fitting

NO	PARTS NAME	MATERIAL	Q'TY
1	BODY	CF8/CF8M CF3/CF3M	1
2	END CAP	CF8/CF8M CF3/CF3M	1
3	BALL	STS304/STS304L STS316/STS316L	1
4	STEM	STS304/STS304L STS316/STS316L	1
5	SEAT	PTFE/RPTFE	2
6	GASKET	PTFE	2
7	THRUST WASHER	PTFE	1
8	STEM O-RING	VITON	1
9	PACKING	PTFE	3
10	METAL RING	STS304	1
11	BELLEVILLE WASHER	STS304	2
12	GLAND	STS304	1
13	BOLT	STS201/STS304	2
14	NUT	STS201/STS304	2
15	NUT	STS201/STS304	4
16	ELASTIC GASKET	STS201/STS304	4
17	BOLT	STS201/STS304	4
18	COVER	ADC12 / NYLONGLASS30%	2
19	ACTUATOR BODY	ADC12	1

품질향상을 위하여 사전 예고없이 사양이 변경 될 수 있습니다.